

TECHNICAL SPECIFICATIONS

Machine Width	:	550mm
Machine Length	:	4450mm
Machine Height	:	1400mm
Line Speed	:	160 pcs/min
Energy	:	400 V
Total Power	:	1.2 kW
Machine Weight	:	250 kg
Engine Power	:	4 kW
Package Dimensions (min)	:	70 x 150mm
Package Dimensions (max)	:	230 x 280mm
Package Weight (max)	:	350 gr
Operator Display		5" High Resolution Color Touch Screen
Memory		1000 products
Machine Material		AISI 304 stainless steel body
Industry / Sectors	:	Pudding, Soup, Chips, Gummy, etc.

** All specifications and feature can be determined upon customer request*

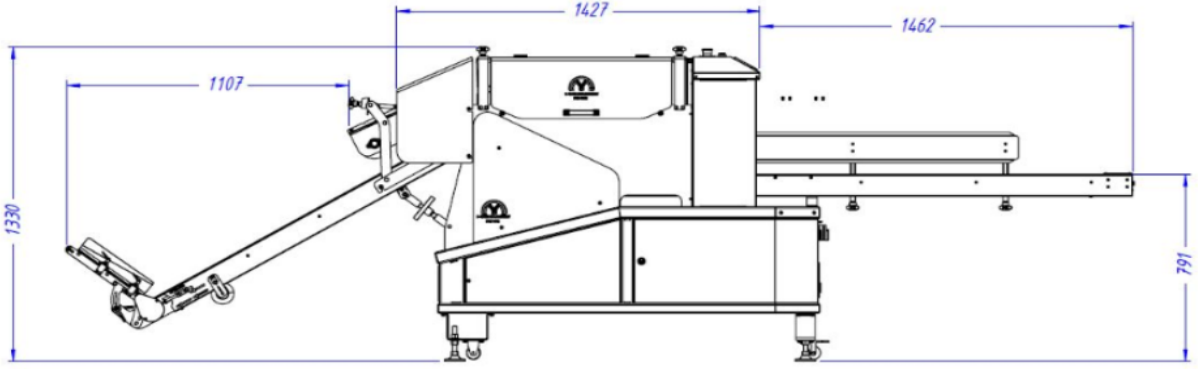

FEATURES

- CE certification
- Compact and hygienic design
- Complying with food production regulations
- Can be integrated into all production lines
- High speed grouping
- Easy and quick size change
- Adjustable conveyor angle and height
- Easy to use operation menus