

**TECHNICAL SPECIFICATIONS**

<b>Machine Weight</b>	:	130 kg (incl. reject system)
<b>Power Supply</b>	:	220V
<b>Power</b>	:	1,5 Kw
<b>Max. Weighing Capacity</b>	:	1 kg
<b>Weighing Accuracy</b>	:	$\pm 0,5 - 2$ gr (max)
<b>Max. Speed</b>	:	180 pcs/min (depending on product dimensions)
<b>Weighing Tray Size</b>	:	200 mm (W) x 310 mm (L)
<b>Reject System</b>	:	Air Push, Mechanical Separation Lever, Push / Fall
<b>Additional Control System</b>	:	Metal Detector
<b>Number Of Conveyor</b>	:	3
<b>Memory</b>	:	100 Products

*\* All specifications and feature can be determined upon customer request*

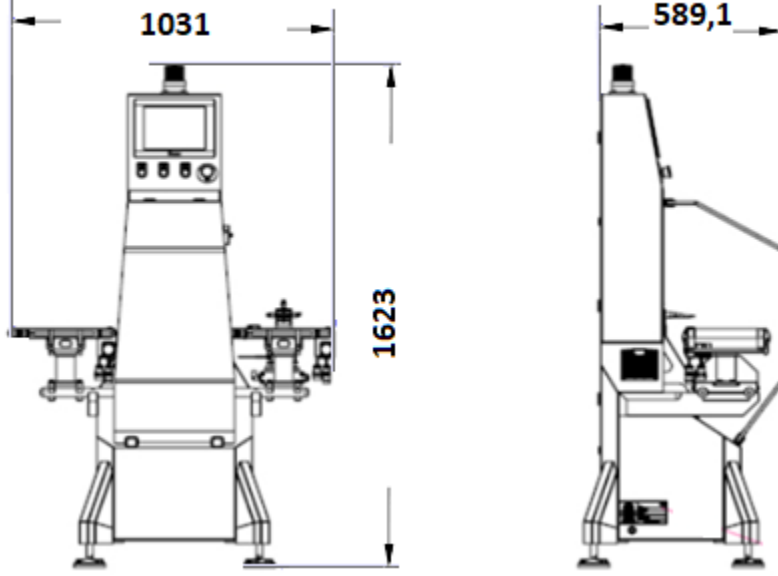

### FEATURES

- CE certification
- Power breaker separately controlling the main energy supply and control unit's power
- Emergency stop buttons accessible from any point
- Modular structural design made of stainless steel material
- Pneumatic and mechanical rejection options for incorrect products
- Simple design enabling easy maintenance
- Designed for ease of use operation menus
- Height and direction adjustable conveyor
- Metal detector for the finished product (optional)
- Servomotor driven conveyors
- Product memory increase (optional)
- Manual and automatic reset options
- High-speed functioning
- Compact and hygienic design
- Various data connection options
- Accessibility via Internet with online connection port
- Internet connection for data transfer (optional)
- Password protected security system
- Stainless steel and long-lasting load cell body
- Easy to use and operator friendly professional software