

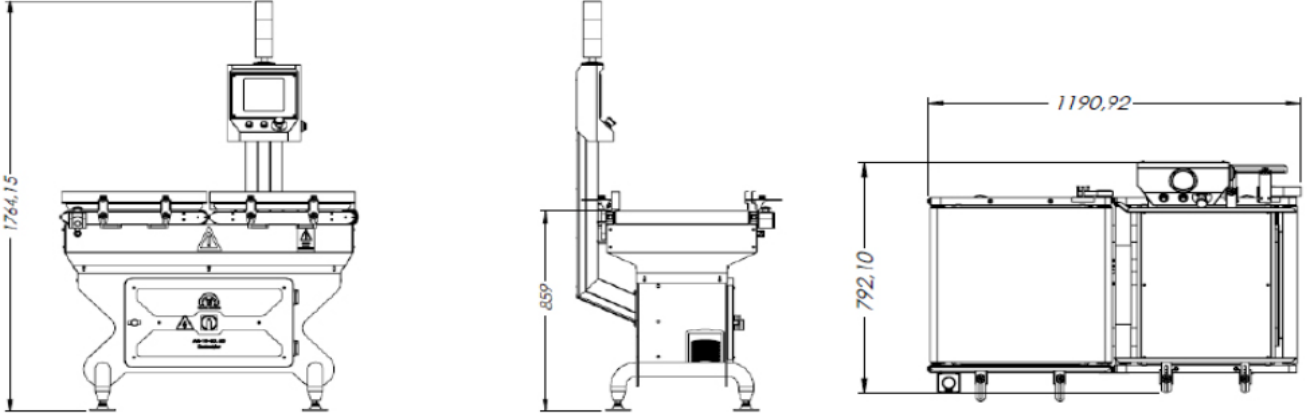

TECHNICAL SPECIFICATIONS

Machine Weight	:	195 kg
Power Supply	:	220V
Power	:	2 Kw
Max. Weighing Capacity	:	10 kg
Weighing Accuracy	:	± 1 - 3 gr (max)
Max. Speed	:	60 pcs/min (depending on product dimensions)
Weighing Tray Size	:	600 mm (W) x 600 mm (H)
Reject System	:	Mechanical Separation Lever, Push / Fall
Additional Control System	:	Metal Detector
Number Of Conveyor	:	2 or 3
Memory	:	100 Products

** All specifications and feature can be determined upon customer request*



FEATURES

- CE certification
- Power breaker separately controlling the main energy supply and control unit's power
- Emergency stop buttons accessible from any point
- Modular structural design made of stainless steel material
- Pneumatic and mechanical rejection options for incorrect products
- Simple design enabling easy maintenance
- Designed for ease of use operation menus
- Height and direction adjustable conveyor
- Metal detector for the finished product (optional)
- Servomotor driven conveyors
- Product memory increase (optional)
- Manual and automatic reset options
- High-speed functioning
- Compact and hygienic design
- Various data connection options
- Accessibility via Internet with online connection port
- Internet connection for data transfer (optional)
- Password protected security system
- Stainless steel and long-lasting load cell body
- Easy to use and operator friendly professional software